

High Performance

- / AC travelling motor applied to provide excellent acceleration, good gradeability, low heat, no carbon brush and maintenance free.
- / The latest CURTIS AC control system provides accurate and stable control to work more efficient.
- / The applied CANBUS structure to offer more reliable and faster command access.
- / Regenerative brake and slope anti-slide function are offered by this truck.
- / Stand-on type with high power drive motor, provides fast travel speed and good gradeability.

Reliability

- / Four-pivot with low centre of gravity design and high strength steel frame structure chassis provide larger residual load capacity and longer working life.
- / Water-proof plugs and connectors applied to provide a reliable protection to electric system.
- / The adopted unique floating suspension system ensures good driving wheels grip and excellent.
- / Top quality hydraulic power unit applied to provide low noise, low vibration, smooth lifting and landing reliable operation.
- / Punch-formed forks to provide more strength and tip guide to provide higher efficient operation.
- / H-type mast profile section to provide more stable and rigid performance.
- / The power plug is fixed on the truck body to avoid damage from battery installment.
- / Pedestrian type use the new design drive system, the drive motor will not accompany the tiller rotation, it can keep all the cable connect to the drive motor avoid being bent.
- / Using non-contact proximity switch, it can provides long life and reliable operation.

Comfort

- / The shock absorption design of foldable platform improves comfort greatly to the operator.
- / The new designed floating suspension driving system, adjustable automatically with loads, offers the driving wheels sufficient power.
- / Simple and beautiful tiller designed to operate all functions easily even by one hand.
- / Displayed turtle speed function applied to move slowly and helps to stack goods in narrow spaces.
- / Optimized designing structure to offer a good visibility and easy entrance of the pallet.
- / The compact body and big rounded design provide an ideal operation in limited space, and the wedge designed chassis greatly increases the passing ability.
- / Customer can choose different width of outside fork and length of forks to fit variable pallet.

Safety

- / With three braking types: releasing brake, reversing brake and emergency brake, the driving safety has been ensured.
- / The applied slope anti-slip function ensures the safety of the operation.
- / The emergency button on the tiller head can effectively avoid the harm to the driver.
- / Soft landing system applied to offer protection to the loads from damaging.
- / Turning speed is automatically reduced when steering only for stand-on.
- / Turtle speed function can keep the slow move when the tiller is vertical direction, the truck can stack goods even in narrow space.
- / Travel speed will be automatically reduced after fork lifting 500mm.

Maintenance

- / AC motor with no cabin brush, don't need maintenance, lower cost.
- / Rear cover can be completely open, operator can see all the components, so the maintenance is very convenient.
- / All shafts installed lubricated shaft sleeve and oil cup, provide convenient maintenance and long service life.

Standard Specification

- / Horn
- / AC drive motor
- / Battery
- / PU drive wheel
- / Tandem wheels
- / Fork lift & lower adopts stepless speed regulating
- / Pedal and handrail
- / Soft landing system
- / 1150mm fork length
- / CURTIS AC controller
- / Hydraulic power unit
- / 570mm outside fork width
- / Emergency disconnect switch
- / Multi-function battery indicator
- / CAN-bus system multi-function tiller
- / Electric steering (stand on pallet stacker)

Options

- / Load backrest
- / Mast protection
- / 240Ah, 340Ah battery
- / Different width of outside fork
- / Different mast lifting heights
- / Cold store protection (-30°C)
- / Side way battery change
- / Different length of forks
- / Overhead guard

2.0t Hi Range Pallet Stacker Truck Specification:

Mast Type	Max Lifting Height h_2	Max. fork height (h_3+h_{13})	Lowered Height h_1	Extended Height h_4	Free lift	Load Capacity at 600mm
						2.0t
Double Cylinder duplex wide view	2000	2090	1647	3647	90	2000
	2500	2590	1897	3147	90	2000
	2700	2790	1997	3347	90	1800
	3000	3090	2147	3647	90	1600
	3300	3390	2297	3947	90	1350
	3500	3590	2397	4147	90	1180
	3600	3690	2447	4247	90	1100
	3800	3890	2547	4447	90	980
	4000	4090	2747	4747	90	950
	4300	4390	2897	5047	90	860
	4500	4590	2997	5247	90	760
Duplex full wide view	2000	2090	1700	2700	1090	2000
	2500	2590	1950	3200	1340	2000
	2700	2790	2050	3400	1440	1800
	3000	3090	2200	3700	1590	1600
	3300	3390	2350	4000	1740	1350
	3500	3590	2450	4200	1840	1180
	3600	3690	2500	4300	1890	1100
Triplex full wide view	3500	3590	1944	4314	1130	1180
	3700	3790	2009	4509	1200	1020
	4000	4090	2109	4809	1300	950
	4300	4390	2209	5109	1400	860
	4500	4590	2259	5259	1500	760
	4700	4790	2359	5559	1500	680
	5000	5090	2454	5844	1610	570
	5200	5290	2509	6009	1700	510
	5500	5590	2609	6309	1800	400



ZHEJIANG HANGCHA IMP. & EXP. CO., LTD.

Factory site: 666 Xiangfu Road,
Hangzhou, Zhejiang, China (311305)

Tel: +86-571-88926735 88926755
Fax: +86-571-88926789 88132890

sales@hcforklift.com
www.hcforklift.com



Follow us on
Facebook



Follow us on
YouTube



Follow us on
WeChat



ISO14001
ISO14001:2015



ISO9001
ISO9001:2015



HANGCHA trucks conform
to the European Safety
Requirements.

HANGCHA GROUP CO., LTD. reserves the right to make any changes without notice concerning colors, equipment, or specifications detailed in this brochure, or to discontinue individual models. The colors of trucks, delivered may differ slightly from those in brochures.

2018 VERSION ZCOPYRIGHT 201812



A Series Pallet Stacker Truck Hi Range

with capacities of 1,200 to 2,000kg

The World of Hangcha



A Series Pallet Stacker Truck Hi Range

		HANGCHA GROUP CO., LTD.																	
Distinguishing mark	1.1	Manufacturer																	
	1.2	Manufacturer's type designation																	
Weight	1.4	Standing	Pedestrian	Standing	Pedestrian	Standing	Pedestrian	Standing	Pedestrian	Standing	Pedestrian	Standing	Pedestrian	Standing	Pedestrian	Standing	Pedestrian	Standing	Pedestrian
	1.5	Q (kg)	1200	1200	1400	1400	1600	1600	2000	2000	1200	1200	1400	1400	1600	1600	2000	2000	2000
	1.6	c (mm)	600	600	600	600	600	600	600	600	600	600	600	600	600	600	600	600	600
	1.9	y (mm)	1425	1425	1425	1425	1425	1425	1425	1425	1425	1425	1425	1425	1425	1425	1425	1425	1425
Tyres, chassis	2.1	kg	1310	1177	1315	1182	1362	1215	1405	1258	1380	1247	1385	1252	1432	1285	1475	1338	
	3.1	Tyres: solid rubber, superelastic, pneumatic, polyurethane																	
	3.2	PU																	
	3.3	PU																	
	3.4	PU																	
	3.5	PU																	
	3.6	PU																	
	3.7	PU																	
Dimensions	4.4	PU																	
	4.15	PU																	
	4.19	PU																	
	4.21	PU																	
	4.22	PU																	
	4.25	PU																	
	4.32	PU																	
	4.34.1	PU																	
	4.34.2	PU																	
	4.35	PU																	
Performance data	5.1	PU																	
	5.2	PU																	
	5.3	PU																	
	5.8	PU																	
	6.1	PU																	
	6.2	PU																	
	6.3	PU																	
	6.4	PU																	
Electric engine	8.1	PU																	
	9.1	PU																	

Note: 1) Triplex Mast+21mm

Li-Ion Battery Specification

Type		CDD12-AC15-1	CDD14-AC15-1	CDD16-AC15-1	CDD20-AC15-1	CTD12-AC15-1	CTD14-AC15-1	CTD16-AC15-1	CTD20-AC15-1
Li-Ion battery	V/Ah	24/150	24/150	24/150	24/150	24/150	24/150	24/150	24/150
Li-Ion battery,Optional	V/Ah	24/200	24/200	24/200	24/200	24/200	24/200	24/200	24/200

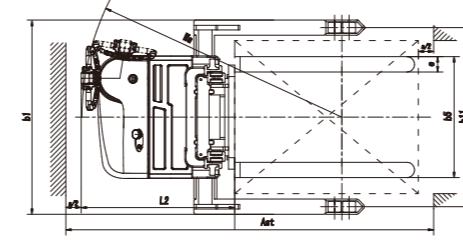
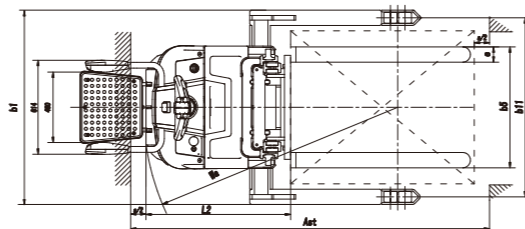
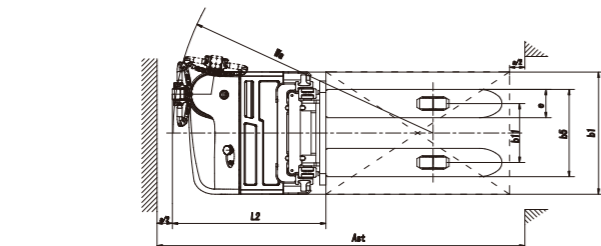
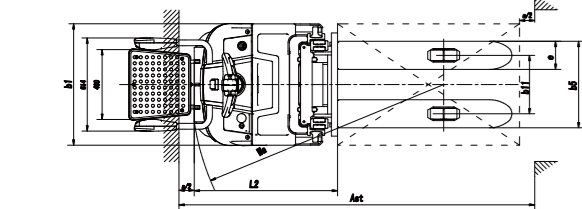
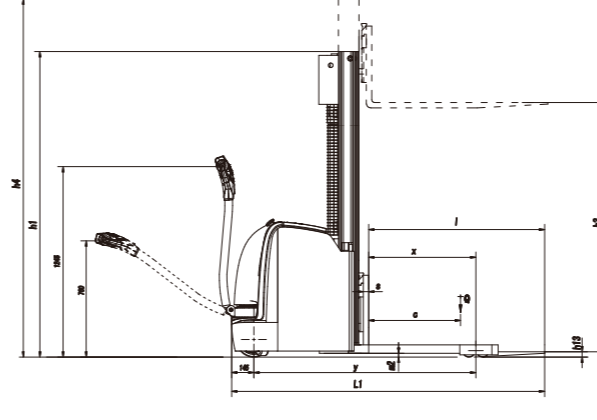
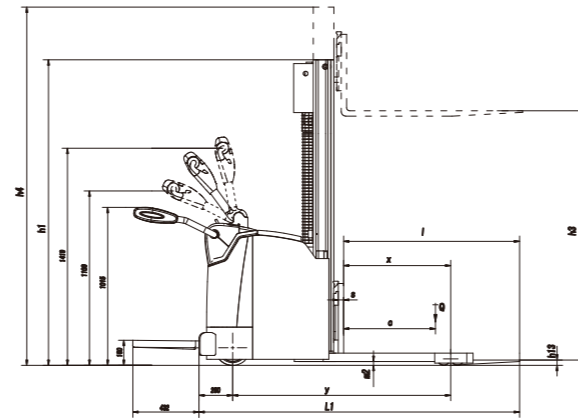
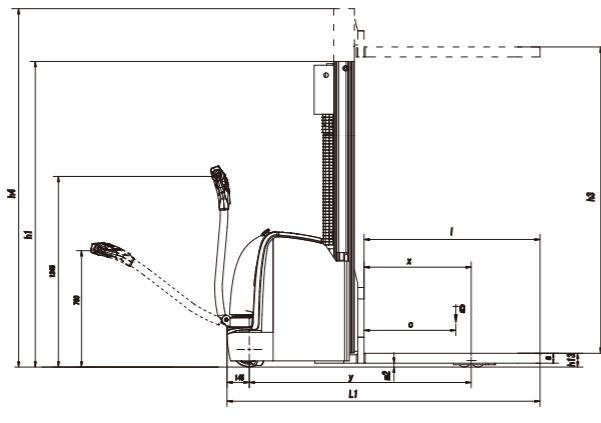
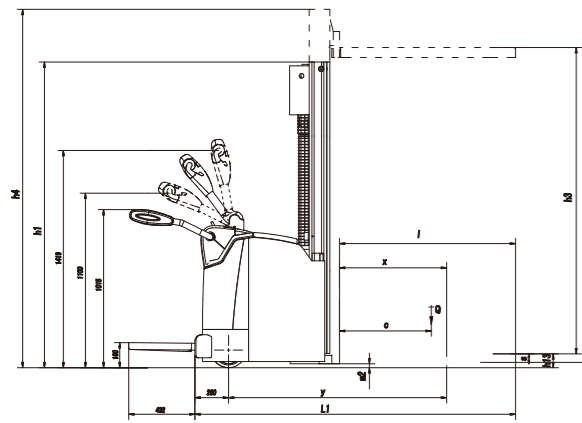

1.2-1.6t Hi Range Pallet Stacker Truck Specification:

Mast Type	Max Lifting Height h ₃	Max. fork height (h ₃ +h ₁₃)	Lowered Height h ₁	Extended Height h ₄	Free lift	Load Capacity at 600mm		
						1.2t	1.4t	1.6t
Double cylinder duplex wide view	mm	mm	mm	mm	mm	Kg	Kg	Kg
	2000	2090	1542	2542	90	1200	1400	1600
	2500	2590	1792	3042	90	1200	1400	1600
	2700	2790	1892	3242	90	1200	1400	1600
	3000	3090	2042	3542	90	1200	1400	1600
	3300	3390	2192	3842	90	1200	1200	1300
	3500	3590	2292	4042	90	1070	1070	1130
	3600	3690	2342	4142	90	1000	1000	1050
	3800	3890	2442	4342	90	920	920	970
	4000	4090	2642	4642	90	850	850	900
Duplex full-free wide view	mm	mm	mm	mm	mm	Kg	Kg	Kg
	4300	4390	2792	4942	90	770	770	810
	4500	4590	2892	5142	90	680	680	710
	2000	2090	1595	2595	1090	1200	1400	1600
	2500	2590	1845	3095	1340	1200	1400	1600
	2700	2790	1945	3295	1440	1200	1400	1600
	3000	3090	2095	3595	1590	1200	1400	1600
	3300	3390	2245	3895	1740	1200	1200	1300
	3500	3590	2345	4095	1840	1070	1070	1130
	3600	3690	2395	4195	1890	1000	1000	1050
Triplex full-free wide view	mm	mm	mm	mm	mm	Kg	Kg	Kg
	3500	3590	1844	4214	1220	1070	1070	1130
	3700	3790	1909	4409	1290	960	960	1050
	4000	4090	2009	4709	1390	850	850	975
	4300	4390	2109	5009	1490	770	770	900
	4500	4590	2159	5159	1590	680	680	810
	4700	4790	2259	5459	1590	600	600	710
	5000	5090	2354	5744	1700	500	500	530
	5200	5290	2409	5909	1790	440	440	470
	5500	5590	2509	6209	1890	320	320	350

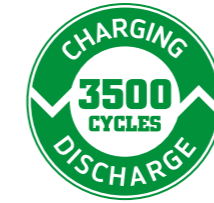

Li-Ion Technology

- / The power supply is lithium iron phosphate battery. Each cell is provided with the safety protection device, and is safe and reliable.
- / With advanced BMS power supply management system, intercommunication between the lithium battery and vehicle controller can be realized in order to conduct real-time monitoring for the battery status. The service life and safety of the battery can be effectively improved.
- / With high multiplying power discharge technology, the forklift still can output strong power at the end of battery discharge period.
- / Charging and discharge efficiency are higher, the forklift can have longer endurance mileage, the battery is energy-saving and environment-friendly.
- / With fast charging technology, the lithium battery can be fully charged within 2h.
- / The lithium battery pack adopts the fully-enclosed structure, and is safe and reliable.
- / The battery is maintenance-free, does not result in heavy-metal pollution, and is green and environment-friendly.

